

# Modular Type Lubricator *AL Series*

Lubricator AL Series	Model	Port size	Options
 <p data-bbox="140 891 276 925">p. 88 to 93</p>	AL20-D	1/8, 1/4	Bracket
	AL30-D	1/4, 3/8	
	AL40-D	1/4, 3/8, 1/2	
	AL40-06-D	3/4	
	AL50-D	3/4, 1	
	AL60-D	1	

# Lubricator

# AL20-D to AL60-D

Symbol

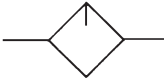

AL30-D

## How to Order

AL **30** - **03** **B** - **—** -D

①
②
③
④
⑤

· Option/Semi-standard: Select one each for a to d.  
 · Option/Semi-standard symbol:  
 When more than one specification is required, indicate in alphanumeric order.  
 Example) AL30-03B-3RW-D

	Symbol	Description	①					
			Body size					
			20	30	40	50	60	
②	—	Rc	●	●	●	●	●	
	N	NPT	●	●	●	●	●	
	F	G	●	●	●	●	●	
+								
③	01	1/8	●	—	—	—	—	
	02	1/4	●	●	●	—	—	
	03	3/8	—	●	●	—	—	
	04	1/2	—	—	●	—	—	
	06	3/4	—	—	●	●	—	
10	1	—	—	—	●	●		
+								
④	—	Without mounting option	●	●	●	●	●	
	B*1	With bracket	●	●	●	●	●	
+								
⑤	a	—	Polycarbonate bowl	●	●	●	●	●
		2	Metal bowl	●	●	●	●	●
		6	Nylon bowl	●	●	●	●	●
		8	Metal bowl with level gauge	—	●	●	●	●
		C	With bowl guard	●	—*3	—*3	—*3	—*3
		6C	With bowl guard (Nylon bowl)	●	—*4	—*4	—*4	—*4
	+							
	b	—	Without drain cock	●	●	●	●	●
		3	With drain cock	●	●	●	●	●
		3W*5	Drain cock with barb fitting	—	●	●	●	●
+								
c	—	Flow direction: Left to right	●	●	●	●	●	
	R	Flow direction: Right to left	●	●	●	●	●	
+								
d	—	Unit on product label: MPa, °C	●	●	●	●	●	
	Z*6	Unit on product label: psi, °F	○*7	○*7	○*7	○*7	○*7	

\*1 Option B is included in the package with the product but does not come assembled. The assembly consists of 2 types of the bracket and 2 mounting screws.

\*2 Refer to chemical data on page 93 for chemical resistance of the bowl.

\*3 A bowl guard is provided as standard equipment (polycarbonate).

\*4 A bowl guard is provided as standard equipment (nylon).

\*5 The combination of metal bowl 2 and 8 is not available.

\*6 For the pipe thread type: NPT

This product is for overseas use only according to the New Measurement Act. (The SI unit type is provided for use in Japan.)

\*7 ○: For the pipe thread type: NPT only

AC  
 AF + AR + AL  
 AW + AL  
 AW + AR  
 AF + AR  
 AF + AFM + AR  
 AW + AFM  
 Attachments  
 AF  
 AFM / AFD  
 AR  
 AL  
 AW

# AL20-D to AL60-D Series

## Standard Specifications

Model	AL20-D	AL30-D	AL40-D	AL40-06-D	AL50-D	AL60-D
Port size	1/8, 1/4	1/4, 3/8	1/4, 3/8, 1/2	3/4	3/4, 1	1
Fluid	Air					
Ambient and fluid temperatures	-5 to 60 °C (No freezing)					
Proof pressure	1.5 MPa					
Max. operating pressure	1.0 MPa					
Min. dripping flow rate*1	15 l/min (ANR)	Port size 1/4: 30 l/min (ANR) Port size 3/8: 40 l/min (ANR)	Port size 1/4: 30 l/min (ANR) Port size 3/8: 40 l/min (ANR) Port size 1/2: 50 l/min (ANR)	50 l/min (ANR)	190 l/min (ANR)	220 l/min (ANR)
Oil capacity	25 cm <sup>3</sup>	55 cm <sup>3</sup>	135 cm <sup>3</sup>			
Recommended lubricant	Class 1 turbine oil (ISO VG32)					
Bowl material	Polycarbonate					
Bowl guard	Semi-standard (Steel)		Standard (Polycarbonate)			
Weight	0.10 kg	0.18 kg	0.37 kg	0.41 kg	0.92 kg	0.99 kg

\*1 The flow rate is 5 drops or greater/min under the following conditions: Inlet pressure of 0.5 MPa; Class 1 turbine oil (ISO VG32); Temperature at 20 °C; Oil adjustment valve fully open. For a circuit that repeatedly turns ON and OFF on the outlet side, make the adjustment so that the average air consumption per minute becomes the minimum dripping flow rate or more.

## Bowl Assembly/Part Nos.

Bowl material	Lubricant exhaust port	Other	Model					
			AL20-D	AL30-D	AL40-D	AL40-06-D	AL50-D	AL60-D
Polycarbonate	Without drain cock	—	C2SL-D	—	—			
		With bowl guard	C2SL-C-D	C3SL-D	C4SL-D			
	With drain cock	—	C2SL-3-D	—	—			
		With bowl guard	C2SL-3C-D	C3SL-3-D	C4SL-3-D			
Drain cock with barb fitting	With bowl guard	—	C3SL-3W-D	C4SL-3W-D				
Nylon	Without drain cock	—	C2SL-6-A	—	—			
		With bowl guard	C2SL-6C-A	C3SL-6-A	C4SL-6-A			
	With drain cock	—	C2SL-36-A	—	—			
		With bowl guard	C2SL-36C-A	C3SL-36-A	C4SL-36-A			
Drain cock with barb fitting	With bowl guard	—	C3SL-36W-A	C4SL-36W-A				
Metal	Without drain cock	—	C2SL-2-A	C3SL-2-A	C4SL-2-A			
		With level gauge	—	C3LL-8-A	C4LL-8-A			
	With drain cock	—	C2SL-23-A	C3SL-23-A	C4SL-23-A			
		With level gauge	—	C3LL-38-A	C4LL-38-A			

\*1 The bowl assembly comes with a bowl seal. Please contact SMC separately for psi and °F unit display specifications.

## Option/Part Nos.

Optional specifications	Model					
	AL20-D	AL30-D	AL40-D	AL40-06-D	AL50-D	AL60-D
Bracket assembly*1	AF24P-070AS	AF34P-070AS	AF44P-070AS	AF49P-070AS	AF54P-070AS	

\*1 The assembly consists of a bracket A/B and 2 mounting screws.

## Replacement Parts

Description	Part no.					
	AL20-D	AL30-D	AL40-D	AL40-06-D	AL50-D	AL60-D
Sight dome assembly	AL20P-080AS					
Lubrication plug assembly	AL24P-060AS	AL34P-060AS	AL44P-060AS			
Bumper retainer assembly	AL20P-030AS	AL30P-030AS	AL40P-030AS	AL54P-030AS	AL60P-030AS	
Bumper	AL20P-040S	AL30P-040S	AL44P-040S	AL60P-040AS		
Bowl seal	C2SFP-260S	C32FP-260S	C42FP-260S			
Bowl assembly*1, *2	Refer to "Bowl Assembly/Part Nos."					

\*1 The bowl assembly comes with a bowl seal.

\*2 Please contact SMC separately for psi and °F unit display specifications.

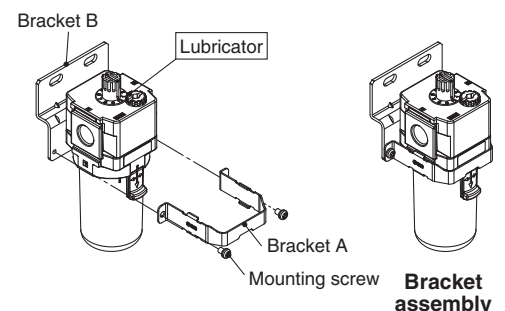

## Flow Rate Characteristics (Representative values)

**AL20-D**

Rc1/4

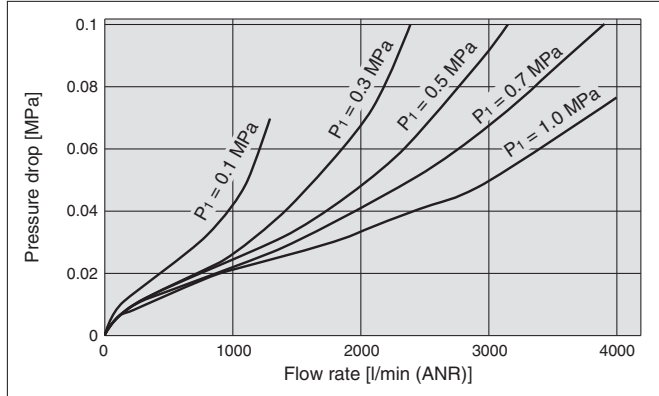

**AL30-D**

Rc3/8

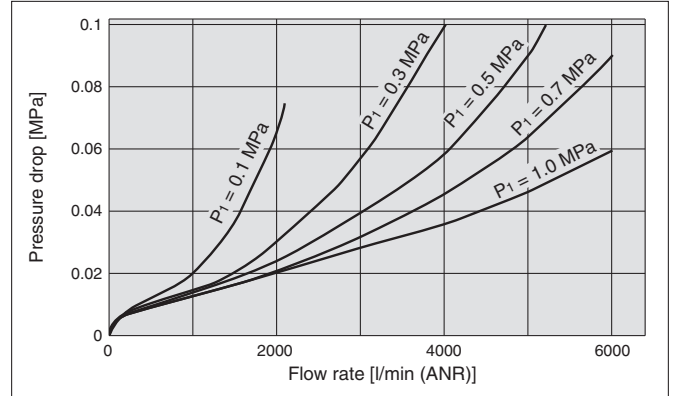

**AL40-D**

Rc1/2

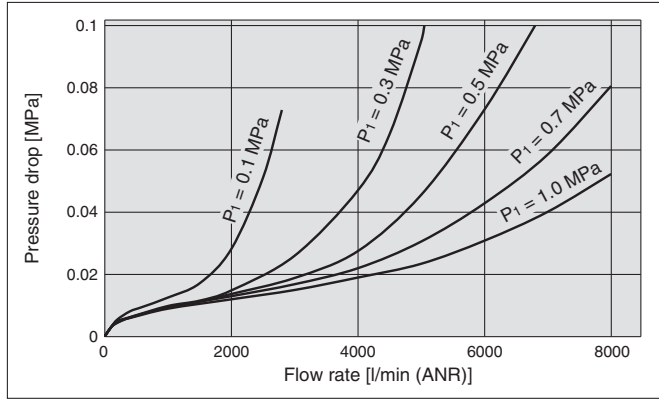

**AL40-06-D**

Rc3/4

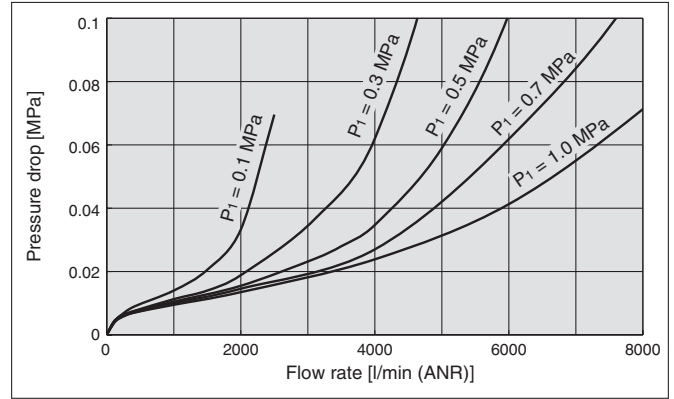

**AL50-D**

Rc1

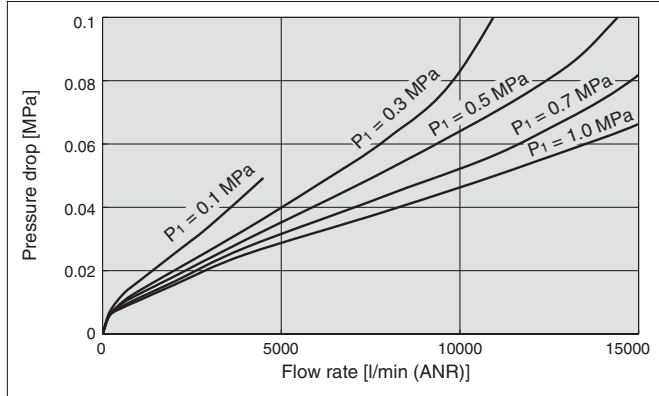

**AL60-D**

Rc1

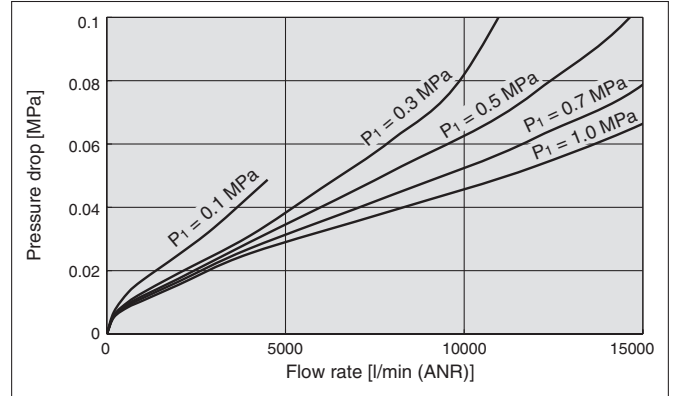

- AC
- AF + AR + AL
- AW + AL
- AF + AR
- AF + AFM + AR
- AW + AFM
- Attachments
- AF
- AFM / AFD
- AR
- AL
- AW

# AL20-D to AL60-D Series

## Dimensions

### AL20-D

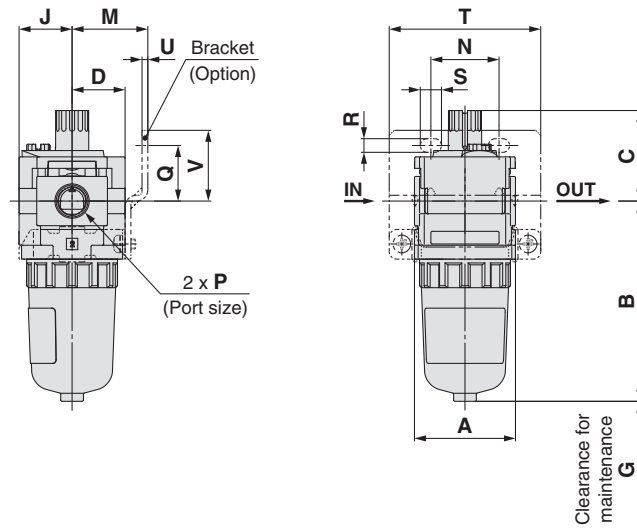

### AL30-D to AL40-06-D

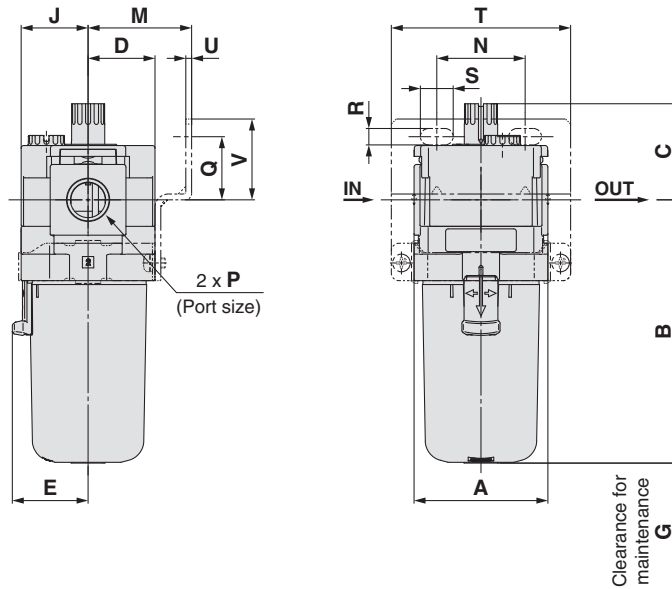

### AL50-D to AL60-D

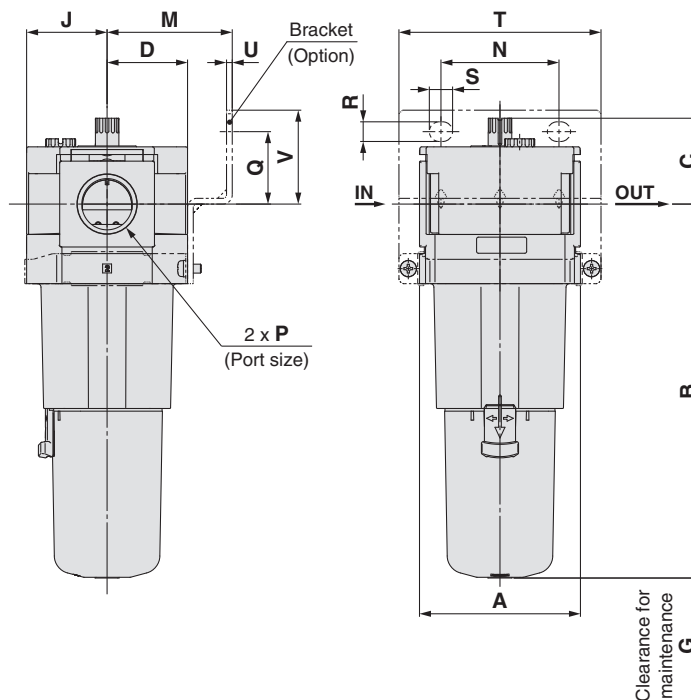

# Lubricator *AL20-D to AL60-D Series*

Applicable model	Semi-standard					
	PC/PA bowl		Metal bowl		Metal bowl with level gauge	
	With drain cock	Drain cock with barb fitting	Without drain cock	With drain cock	Without drain cock	With drain cock
<b>AL20-D</b>						
<b>AL30-D to AL60-D</b>		 Barb fitting applicable tubing: T0604				

Model	Standard specifications								Optional specifications							
	P	A	B	C	D	E	G	J	Bracket mount							
									M	N	Q	R	S	T	U	V
<b>AL20-D</b>	1/8, 1/4	40	79.3	35.9	21	—	60	21	30	27	22	5.4	8.4	60	2.3	28
<b>AL30-D</b>	1/4, 3/8	53	104.3	38.1	26.5	30	80	26.5	41	35	25	6.5	13	71	2.3	32
<b>AL40-D</b>	1/4, 3/8, 1/2	70	136.1	44	35.5	38.4	110	35.5	50	52	30	8.5	12.5	88	2.3	39
<b>AL40-06-D</b>	3/4	75	138.1	44	35.5	38.4	110	35.5	50	52	34	8.5	12.5	88	2.3	43
<b>AL50-D</b>	3/4, 1	90	209.1	48	45	—	110	45	70	66	40.5	11	13	113	3.2	52.5
<b>AL60-D</b>	1	95	223.1	48	45	—	110	45	70	66	40.5	11	13	113	3.2	52.5

Model	Semi-standard specifications					
	PC/PA bowl		Metal bowl		Metal bowl with level gauge	
	With drain cock	With barb fitting	Without drain cock	With drain cock	Without drain cock	With drain cock
	<b>B</b>	<b>B</b>	<b>B</b>	<b>B</b>	<b>B</b>	<b>B</b>
<b>AL20-D</b>	87.6	—	84.5	87.4	—	—
<b>AL30-D</b>	115.4	123.9	104.3	117.8	124.3	137.8
<b>AL40-D</b>	147.1	155.6	136	149.5	156.1	169.5
<b>AL40-06-D</b>	149.1	157.6	138	151.5	158.1	171.5
<b>AL50-D</b>	220.1	228.6	209	222.5	229	242.5
<b>AL60-D</b>	234.1	242.6	223	236.5	243	256.5

AC

AF + AR + AL

AW + AL

AF + AR

AF + AR

AF + AFM + AR

AF + AFM

AW + AFM

Attachments

AF

AFM / AFD

AR

AL

AW



# AL-D Series Specific Product Precautions

Be sure to read this before handling the products. Refer to the back cover for safety instructions. For F.R.L. units precautions, refer to the “Handling Precautions for SMC Products” and the “Operation Manual” on the SMC website: <https://www.smc.eu>

## Design / Selection

### Warning

- Do not introduce air from the outlet side as this can damage the bumper.
- The standard bowl and sight dome of the lubricator is polycarbonate. Do not use in an environment where they are exposed to or come in contact with organic solvents, chemicals, cutting oil, synthetic oil, alkali, and thread lock solutions.

#### Chemical resistance of polycarbonate bowl with sight dome and nylon bowl with sight dome

Type	Chemical name	Application examples	Material	
			Polycarbonate	Nylon
Acid	Hydrochloric acid Sulfuric acid Phosphoric acid Chromic acid	Acid washing liquid for metals	△	×
Alkaline	Sodium hydroxide (Caustic soda) Potash Calcium hydroxide (Slack lime) Ammonia water Sodium carbonate	Degreasing of metals Industrial salts Water-soluble cutting oil	×	○
Inorganic salts	Sodium sulfide Potassium nitrate Sodium sulfate	—	×	△
Chlorine solvents	Carbon tetrachloride Chloroform Ethylene chloride Methylene chloride	Cleansing liquid for metals Printing ink Dilution	×	△
Aromatic series	Benzene Toluene Paint thinner	Coatings Dry cleaning	×	△
Ketone	Acetone Methyl ethyl ketone Cyclohexane	Photographic film Dry cleaning Textile industries	×	×
Alcohol	Ethyl alcohol IPA Methyl alcohol	Antifreeze Adhesives	△	×
Oil	Gasoline Kerosene	—	×	○
Ester	Phthalic acid dimethyl Phthalic acid diethyl Acetic acid	Synthetic oil Anti-rust additives	×	○
Ether	Methyl ether Ethyl ether	Brake oil additives	×	○
Amino	Methyl amino	Cutting oil Brake oil additives Rubber accelerator	×	×
Others	Thread-lock fluid Seawater Leak tester	—	×	△

○: Essentially safe △: Some effects may occur. ×: Effects will occur.

When the above factors are present, or there is some doubt, use a metal bowl for safety.

## Design / Selection

### Caution

- When the piping is branched on the inlet side, install a check valve to prevent the lubricant from back flowing.

## Maintenance

### Warning

- For the AL20-D, replenish the lubricant after releasing the inlet pressure. Lubrication cannot take place under a pressurised condition.
- Tighten the lubrication plug to the recommended tightening torque. Insufficient tightening torque may cause loosening or defective sealing. Excessive tightening torque may damage the thread, etc.

#### Recommended Torque

Unit: N·m

Model	AL20-D	AL30-D	AL40-D AL40-06-D AL50-D AL60-D
Torque	0.25 to 0.35	0.35 to 0.45	0.5 to 0.6

- Adjustment of the oil regulating valve (sight dome assembly) for models from the AL20-D to AL60-D should be carried out manually. Turning it counterclockwise increases the dripping amount, and turning it clockwise reduces the dripping amount. The use of tools can result in damage to the unit. From the fully closed position, three rotations will bring it to the fully open position. Do not rotate it any further than this. Note that the numbered scale markings are guidelines for adjusting the position, and not indicators of the dripping amount.

## Mounting / Adjustment

### Caution

- When the lubricator bowl is installed on the AL30-D to AL60-D, install them so that the lock button lines up to the groove of the front (or the back) of the body to avoid drop or damage of the bowl.

